

Reconfigurable Antennas for Radar Applications

Electronically reconfigurable antennas for communications and radar applications

This invention enables mechanically deployable and electronically reconfigurable antennas for communications and radar applications. The complexity of antenna design is reduced by replacing multiple mission-specific antennas with a single reconfigurable antenna. Embedding an antenna in an expandable accordion lantern allows reconfiguration of the antenna's electronic properties during deployment. Additional antenna geometries show potential for widely varying resonance and gain characteristics depending on shape and size of origami structure and antenna. This suggests broad potential for reconfigurable antenna design.

Summary Bullets

- **Innovative** — Origami-based accordion structure enables variable physical deployment of antenna
- **Reconfigurable** — Varying extent of physical deployment reconfigures antenna frequency band, radiation pattern, and gain
- **Cost-reductive** — Configurability allows for changing complexity of antenna packages

Solution Advantages

- **Innovative** — Origami-based accordion structure enables variable physical deployment of antenna
- **Reconfigurable** — Varying extent of physical deployment reconfigures antenna frequency band, radiation pattern, and gain
- **Cost-reductive** — Configurability allows for changing complexity of antenna packages

Potential Commercial Applications

- Wireless systems
- Cellular radio systems
- Radar systems
- Satellite and space communications
- Aircraft and unmanned airborne vehicles (UAVs)
- Smart weaponry

Background and More Information

For systems needing transportation prior to use, deployable antennas can prevent damage during transport by enabling transformation from a compact (protected) form into an expanded (functional) form for application. By replacing the multiple single function antennas required to support different standards (such as UMTS, Bluetooth, WiFi, WiMAX, DSRC), reconfigurable antenna can reduce cost, form factor, and complexity in a communications or radar systems. Incorporating elements of origami enables antenna designs that are both reconfigurable and deployable.

Inventors

- Dr. Stavros Georgakopoulos
Assistant Professor - Florida International University
- Dr. Emmanouil Tentzeris
Professor - Georgia Tech School of Electrical and Computer Engineering
- Benjamin Cook
Graduate Research Assistant - Georgia Tech School of Electrical and Computer Engineering

IP Status

:

Publications

, -

Images

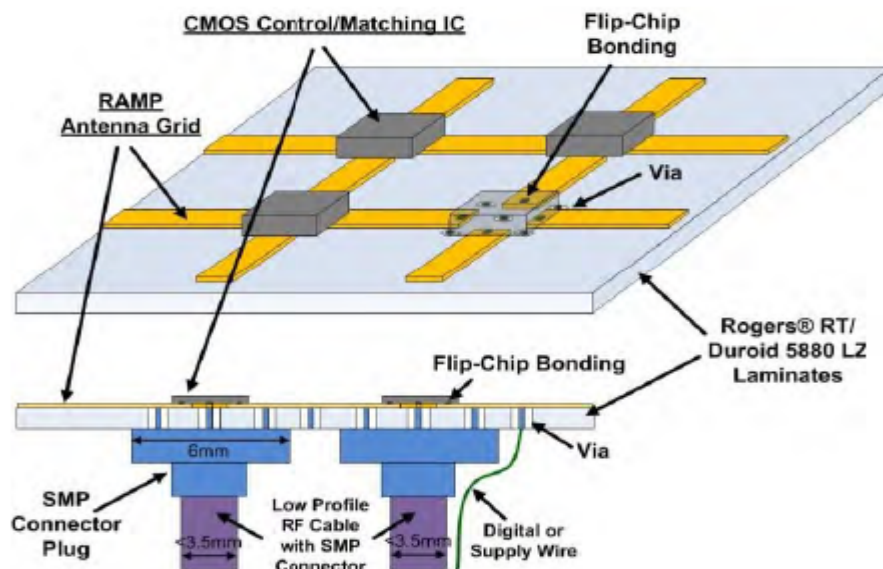

Visit the Technology here:

[Reconfigurable Antennas for Radar Applications](#)

<https://s3.sandbox.research.gatech.edu//print/pdf/node/3713>