

# Adaptive Broadband Impedance Matching in Ultrasound Front-End Electronics

---

## High-performance frequency response for imaging and sensing applications

This tunable active matching network for capacitive ultrasonic micromachined transducers (CMUTs) improves imaging performance in a broad bandwidth. Adding Georgia Tech's network at the interface of the CMUT and its electronics reduces acoustic reflections and increases power transfer by negating the effect of the CMUT capacitance.

In simulations, Georgia Tech researchers determined that the optimum impedance condition for maximum power transfer may not coincide with the minimum acoustic reflectivity. So, they included a tunable negative capacitor circuit for CMUTs which would be applicable for device operating both in collapsed and non-collapsed mode. Their innovation is especially useful for collapsed mode CMUTs where capacitance and frequency response changes significantly with direct current bias. Georgia Tech's approach ensures that the matching circuit operates at the optimum or near-optimum level as CMUT capacitance changes.

This impedance matching can enhance not only signal-to-noise ratio but also improve the uniformity of the array element response, since it reduces the acoustic scattering and crosstalk between array elements. This network innovation also works with piezoelectric micromachined ultrasonic transducers (PMUTs) and bulk piezoelectric transducers.

## Summary Bullets

- **High performance:** Improves power transfer and acoustic reflectivity
- **Flexible:** Enables multimodal and tunable operation of CMUTs
- **Efficient:** Provides optimal matching for co-design of CMUT electronics

## Solution Advantages

- **High performance:** Improves power transfer and acoustic reflectivity
- **Flexible:** Enables multimodal and tunable operation of CMUTs
- **Efficient:** Provides optimal matching for co-design of CMUT electronics
- **Accurate:** Improves bandwidth and SNR for more accurate imaging

## Potential Commercial Applications

- Medical ultrasound imaging, including intravascular and intracardiac ultrasound imaging
- Nondestructive testing, underwater acoustic imaging

## Background and More Information

CMUTs are used in multiple applications, including imaging and sensing. They utilize semiconductor fabrication processes, allowing lower integration cost and higher yield as compared with conventional piezoelectric transducers, especially when small and multiple element arrays are required. Tight integration of CMUT arrays with integrated circuits can make active impedance matching techniques feasible to improve electrical power transfer and reduce acoustic reflectivity. This Georgia Tech innovation demonstrates that negative capacitance-based impedance matching improves performance, which can impact image quality and power transfer for a variety of ultrasound applications.

## Inventors

- Dr. Ahmad Rezvanitabar  
Senior Graduate Research Assistant - Georgia Tech Institute for Electronics and Nanotechnology
- Dr. Evren Arkan  
Postdoctoral Researcher - Georgia Institute of Technology
- Dr. F. Degertekin  
George W. Woodruff Chair in Mechanical Systems and Professor - Georgia Tech School of Mechanical Engineering

## IP Status

<p>Patent application has been filed</p>: US63/058122

## Publications

[Analysis of Negative Capacitance Based Broadband Impedance Matching for CMUTs](#), IEEE Transactions on Ultrasonics, Ferroelectrics, and Frequency Control - May 13, 2021

## Images

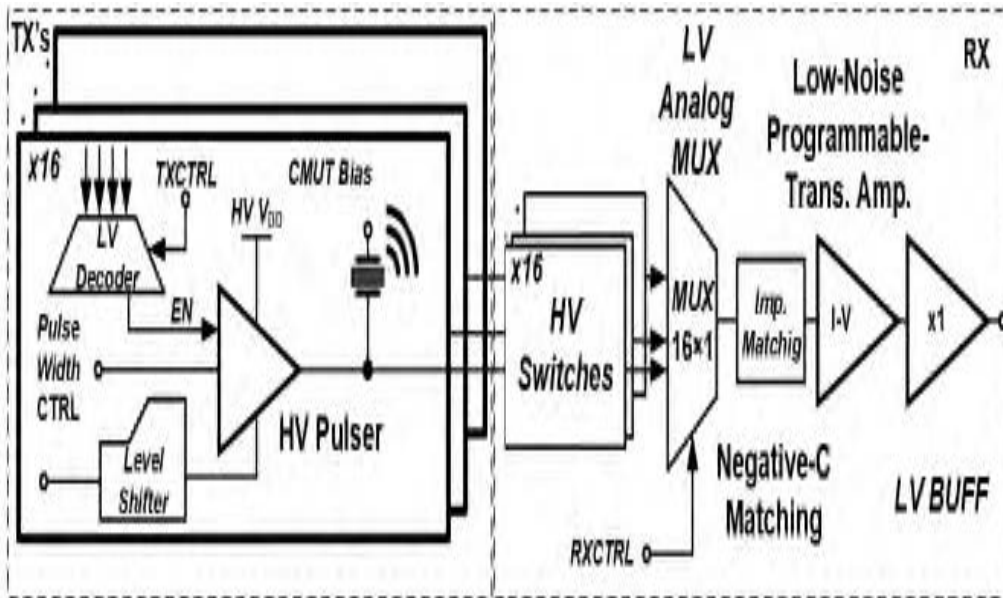

Simplified block diagram of the proposed architecture of the ultrasound receiver with the element-level impedance matching for low frame rate applications such as intracranial ultrasound

Visit the Technology here:

[Adaptive Broadband Impedance Matching in Ultrasound Front-End Electronics](https://s3.sandbox.research.gatech.edu/print/pdf/node/3314)

<https://s3.sandbox.research.gatech.edu/print/pdf/node/3314>