

# Flexible Power Generation with Negative Carbon Emissions

---

## Uses low-cost natural gas for electricity generation while reducing CO<sub>2</sub> in the environment

This new approach for flexible power generation produces energy with negative CO<sub>2</sub> emissions and can dramatically reduce the cost of a net-zero carbon system. The modular system combines a natural gas combined cycle (NGCC) power plant, a conventional post-combustion carbon capture (PCC) system, and a direct air capture (DAC) system.

Georgia Tech's technology achieves positive power with a negative carbon footprint across a wide range of operation of an NGCC plant from 100% to 25% of full load. The modular nature of the DAC system allows for partial operation, making it highly flexible and allowing power generators to respond to variable renewable energy (VRE) production. Emissions are reduced by up to 97% with the conventional PCC and then further reduced to negative with DAC. The system takes advantage of variable electricity pricing by changing the amount of DAC —increasing the amount of DAC when the electricity price is low and decreasing when it is high.

## Summary Bullets

- **Energy security:** This system enables the continued use of low-cost domestic fuel (i.e., natural gas) for electricity generation and increases the reliability of U.S. electricity production.
- **Environmental protection:** Flexible carbon capture and storage (CCS) systems can achieve high CO<sub>2</sub> capture rates from flue gas. For example, with this system a power generator could shift the times it exports electricity to the grid, allowing the power generator and CCS plant to operate under steady-state conditions and with reduced emissions.
- **Reduced costs:** The cost of a net-zero carbon electricity system is lowered by providing dispatchable power to a high-VRE grid.

## Solution Advantages

- **Energy security:** This system enables the continued use of low-cost domestic fuel (i.e., natural gas) for electricity generation and increases the reliability of U.S. electricity production.
- **Environmental protection:** Flexible carbon capture and storage (CCS) systems can achieve high CO<sub>2</sub> capture rates from flue gas. For example, with this system a power generator could shift the times it exports electricity to the grid, allowing the power generator and CCS plant to operate under steady-state

conditions and with reduced emissions.

- **Reduced costs:** The cost of a net-zero carbon electricity system is lowered by providing dispatchable power to a high-VRE grid.
- **Scalable:** The technology can be scaled up for direct atmospheric capture of CO<sub>2</sub>.
- **Efficient:** The DAC unit has the ability to treat gas streams with relatively low concentration of CO<sub>2</sub>.

## Potential Commercial Applications

This technology is particularly applicable to CCS-equipped power plants in high VRE environments.

## Background and More Information

Power plants equipped with CCS technologies can reduce the cost of net-zero carbon systems, but the addition of VRE sources like wind and solar can make them difficult to design and operate. Increased cyclic operation of electricity generators could also reduce capacity and efficiency, increase operations and maintenance costs, and potentially increase CO<sub>2</sub> emissions. Georgia Tech's system is designed to improve CCS processes and enable dispatchable, low-cost, net-zero carbon power generation.

## How It Works

This system integrates an NGCC plant with a conventional amine capture system and DAC. The integration involves taking steam from the heat generation and recovery system of the natural gas plant for use in the reboiler of the amine capture plant, as well as extracting low-temperature heat to use for DAC. The amount of low-temperature heat can be varied to increase the amount of DAC during times when the electricity price is low and decreased when it is high. The state of the DAC system is optimized to take advantage of the variable price. The NGCC plant runs continuously with the conventional PCC system removing CO<sub>2</sub> at its most efficient level. In times of low demand, steam and power from the natural gas plant remove CO<sub>2</sub> from the atmosphere.

## Inventors

- Dr. Matthew Realf  
Professor and David Wang Sr. Fellow - Georgia Tech School of Chemical and Biomolecular Engineering
- Dr. Fani Boukouvala  
Assistant Professor - Georgia Tech School of Chemical and Biomolecular Engineering
- Dr. Christopher Jones  
Professor - Georgia Tech School of Chemical and Biomolecular Engineering
- Dr. Ryan Lively  
Assistant Professor – Georgia Tech School of Chemical and Biomolecular Engineering
- Dr. Joseph Scott  
Associate Professor - Georgia Tech School of Chemical and Biomolecular Engineering
- Dr. David Thierry  
Former Post Doctoral Research - Georgia Tech Scott Research Group

## IP Status

<p>Patent application has been filed</p>: US63/280606

## Publications

[Positive Power with Negative Emissions: Flexible NGCC Enabled by Modular Direct Air Capture \(DAC\)](#),  
Presentation at National AIChE Meeting - November 11, 2021

## Images

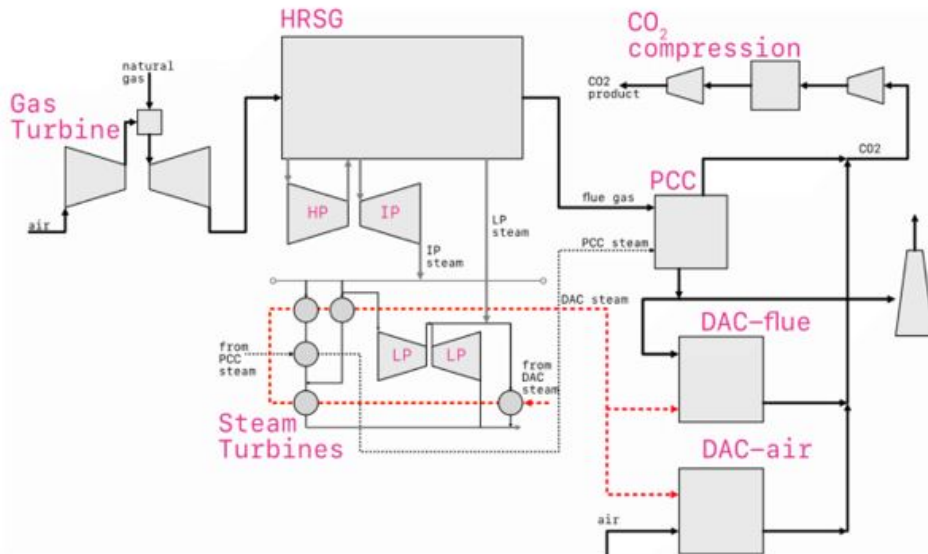

Simplified block diagram of the flexible power generation plant

Visit the Technology here:

[Flexible Power Generation with Negative Carbon Emissions](#)

---

<https://s3.sandbox.research.gatech.edu/print/pdf/node/3267>